

Nr części Part no.	Opis	Description	Materiał		
			FG166663TGP	FG166663TKP	FGF66663TP
1	Korpus	Body	1.4408		
2	Część korpusu	Body connector	1.4408		
3	Kula	Ball	1.4408		
4	Walek sterujący	Stem	1.4542		
5*	Pierścień osadzenia	Seat	PTFE / szkło PTFE / glass	PTFE / węgiel PTFE / carbon	PTFE PTFE
6*	Uszczelnienie wałka sterującego	Stem packing	PTFE	PTFE	Grafit Graphite
7*	Tarcza ślizgowa	Thrust washer	PTFE / węgiel - PTFE / carbon		
8*	Uszczelnienie pierwot.	Primary sealing	PTFE / szkło - PTFE / glass		
9*	Tarcza naciskowa	Thrust washer	PTFE / węgiel - PTFE / carbon		
10	Dławica	Gland	1.4301		
11	Sprężyna krążkowa	Disc spring washer	1.4310		
14	Śruba cylindr/nakrętka	Cylinder screw / nut	DIN 912 / DIN 934 - A2 / Stainless steel		
16	Wykonanie antystat.	Antistatic device	1.4301		
17*	Uszczelnienie korpusu	Body seal	1.4401/grafit 1.4401/graphite		
18	Śr. z dwustr. gwintem	Stud bolt	Stal k/o - A2 / Stainless steel		
19	Nakrętka sześciokątna	Hexagon nut	DIN 934 - A2 / Stainless steel		
20	Otwory dławicy	Gland flange	1.4308		
21	Śruba sześciokątna	Hexagon screw	DIN 933 - A2 / Stainless steel		
22	Płyta zderzakowa	Stop plate	1.4308		
23	Trójnik	T-piece	1.4308		
24	Rura	Pipe	Stal k/o / Stainless steel		
25	Śruba cylindryczna	Cylinder screw	DIN 912 - A2 / Stainless steel		
26	Tarcza	Washer	1.4301		

* = części zużywające się / wearing parts

FGF = Firesafe

 Wybór innego materiału na zapytanie
 Other materials available

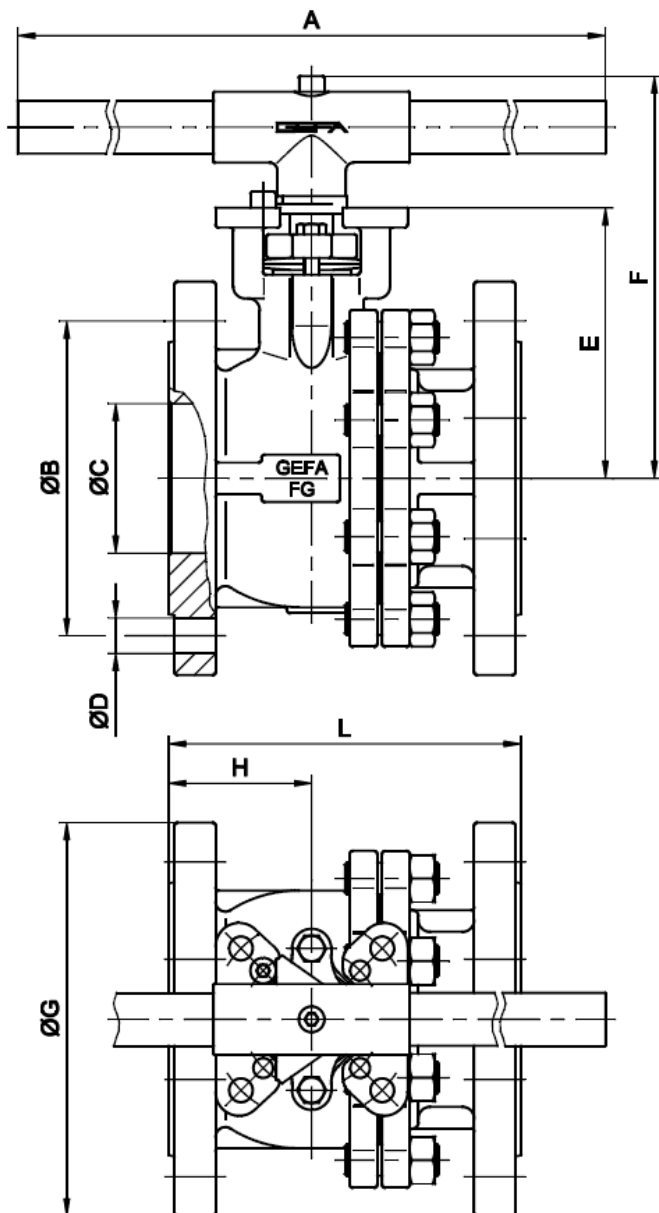

MULTITOP

Przyłącze napędu:
DIN 3337 / ISO 5211

Długość zabudowy:
DIN 3202 – F4
EN 558-1 – Typoszereg 27

Kołnierze:
DIN 2501 – PN 40

MULTITOP
Mounting plate:
DIN 3337 / ISO 5211

Face to face dimension:
DIN 3202 – F4
EN 558-1 – line 27

Flanges:
DIN 2501 – PN 40

DN	NPS	PN	A	ØB	ØC	ØD	E	F*	ØG	H	L	kg
65	2 1/2"	16	400	145	64	4x18	131	198	185	71	170	14
80	3"		400	160	76	8x18	138	205	200	73	180	18
100	4"		500	180	100	8x18	155	222	220	83	190	24
65	2 1/2"	40	400	145	64	8x18	131	198	185	71	170	16
80	3"		400	160	76	8x18	138	205	200	73	180	20
100	4"		500	190	100	8x22	155	222	235	83	190	28

Waga włącznie z dźwignią ręczną / Weight including hand lever

* Opcja: wydłużenie o 100mm zabudowy dla izolacji
* Option: length increased by 100mm for insulation

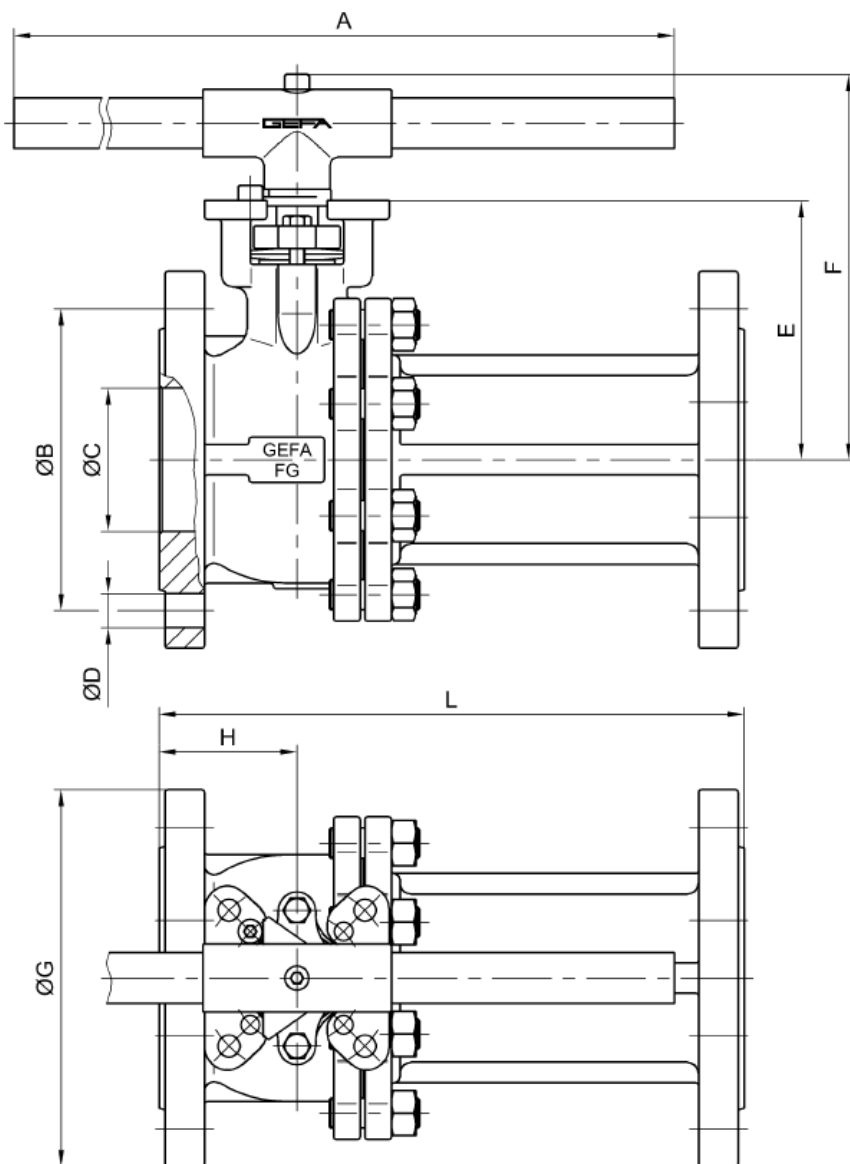

MULTITOP
Przyłącze napędu:
DIN 3337 / ISO 5211

Długość zabudowy:
DIN 3202 – F1
EN 558-1 – Typoszereg 28

Kołnierze:
DIN 2501 – PN 40

MULTITOP
Mounting plate:
DIN 3337 / ISO 5211

Face to face dimension:
DIN 3202 – F1
EN 558-1 – line 28

Flanges:
DIN 2501 – PN 40

DN	NPS	PN	A	ØB	ØC	ØD	E	F*	ØG	H	L	kg
65	2 1/2"	16	400	145	64	4x18	131	198	185	71	290	14
80	3"		400	160	76	8x18	138	205	200	73	310	18
100	4"		500	180	100	8x18	155	222	220	83	350	24
65	2 1/2"	40	400	145	64	8x18	131	198	185	71	290	16
80	3"		400	160	76	8x18	138	205	200	73	310	20
100	4"		500	190	100	8x22	155	222	235	83	350	28

Waga włącznie z dźwignią ręczną / Weight including hand lever

* Opcja: wydłużenie o 100mm zabudowy dla izolacji
* Option: length increased by 100mm for insulation

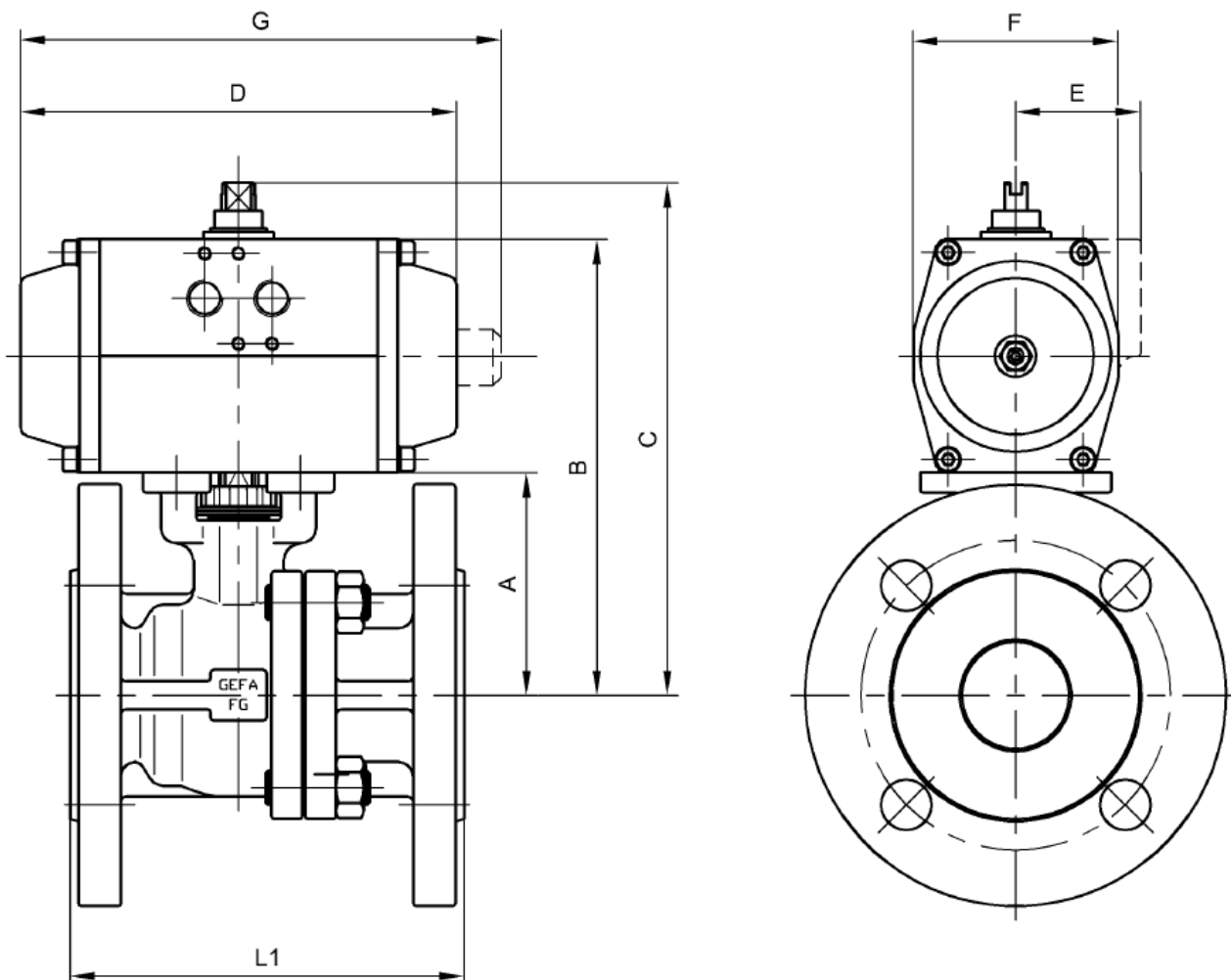

DN	Typ napędu Actuator type	A	B	C	D	E	F	G*	L1
15	AP(M)1	50	117	137	142	41	60	162	115
	AP(M)2		133	153	155	45	73	171	
	AP(M)3		150	170	213	50	85	240	
20	AP(M)1	55	122	142	142	41	60	162	120
	AP(M)2		138	158	155	45	73	171	
	AP(M)3		155	175	213	50	85	240	
25	AP(M)2	62	145	165	155	45	73	171	125
	AP(M)3		162	182	213	50	85	240	
32	AP(M)2	74	157	177	155	45	73	171	130
	AP(M)3		174	194	213	50	85	240	
40	AP(M)3	79	179	199	213	50	85	240	140
	AP(M)3,5		189	209	236	53	98	268	
	AP(M)4		204	224	276	58	110	304	
	AP(M)4		204	224	276	58	110	304	

DN	Typ napędu Actuator type	A	B	C	D	E	F	G*	L1
50	AP(M)3	87	187	207	213	50	85	240	150
	AP(M)3,5		197	217	236	53	98	268	
	AP(M)4		212	232	276	58	110	304	
65	AP(M)3,5	131	241	261	236	53	98	268	170
	AP(M)4		256	276	276	58	110	304	
	AP(M)4,5		273	303	310	69	128	350	
80	AP(M)4	138	263	283	276	58	110	304	180
	AP(M)4,5		280	310	310	69	128	350	
	AP(M)5		293	323	366	-	140	405	
100	AP(M)4	155	280	300	276	58	110	304	190
	AP(M)4,5		297	327	310	69	128	350	
	AP(M)5		310	340	366	-	140	405	

* Wymiar G tylko dla serii APM / Dimension G only for APM series

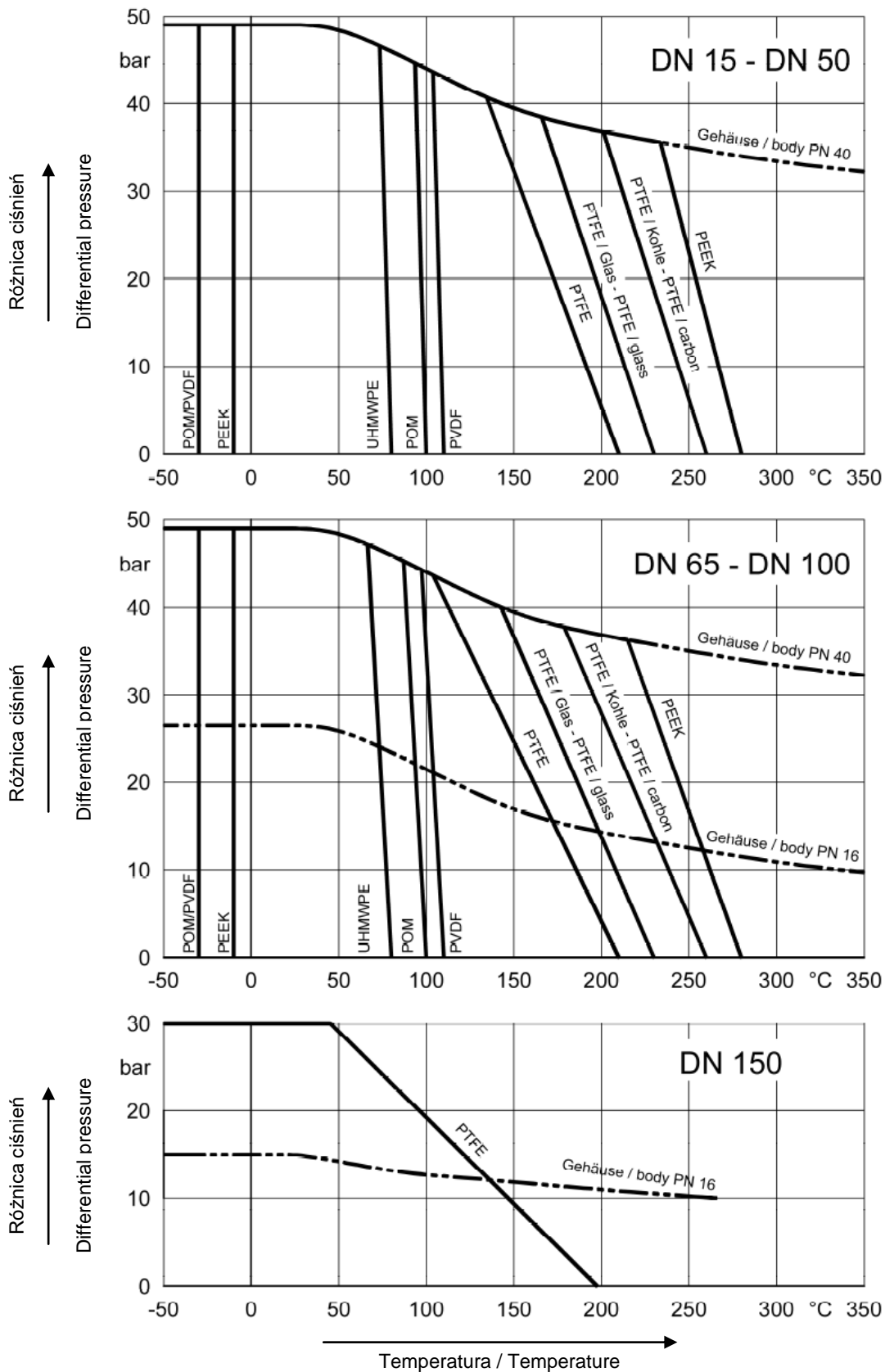

DN	Przyłącze napędu Actuator mounting connection Kołnierz / Flange DIN 3337 / ISO 5211	Moment obrotowy Nm Breakaway torque Nm Pełny przelot Full bore			Wartości przepływu Kvs Flow coefficient Kvs Pełny przelot Full bore
		Ciśnienie robocze / Working pressure			
		0 bar	16 bar	40 bar	
15	F04/F05	10	11	12,5	20
20	F04/F05	10	11	12,5	40
25	F04/F05	15	16,5	19	75
32	F04/F05	25	27,5	31,5	130
40	F05/F07	35	38,5	44	170
50	F05/F07	50	55	62,5	270
65	F07/F10	70	77	87,5	550
80	F07/F10	100	110	125	1000
100	F07/F10	125	137,5	156,5	1650
150	F10/F12	250	275	312,5	4200

Momenty obrotowe odnoszą się do pierścienia osadzenia wykonanego z PTFE, PTFE/szkło lub PTFE/węgiel. W przypadku zaworów kulowych z pierścieniem osadzenia z PEEK podane wartości momentu obrotowego należy zwiększyć o 1,5.

Podane wartości to wartości momentów zerwania dla wody w temperaturze otoczenia.

Momenty zerwania mogą różnić się w zależności od medium, temperatury i częstotliwości użycia.

Torques refer to ball valves with seats made of PTFE, PTFE/glass or PTFE/carbon.

For ball valves with PEEK seats, the specified torques must be increased by the factor 1,5.

The mentioned values are breakaway torques, based on medium water at ambient temperature.

The breakaway torques may vary acc. to medium, temperature and frequency of operations.

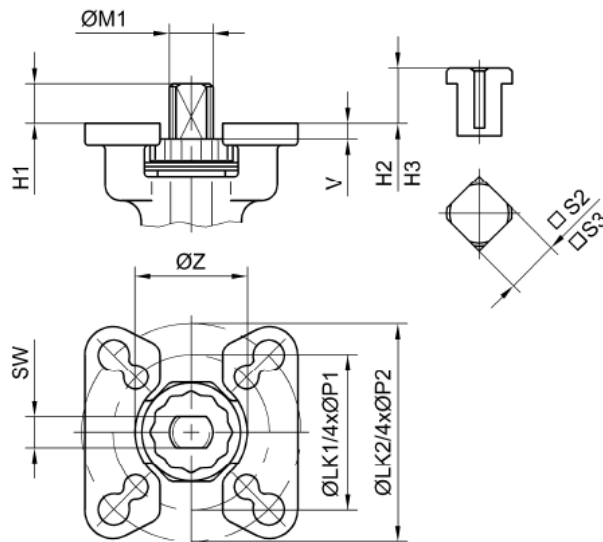
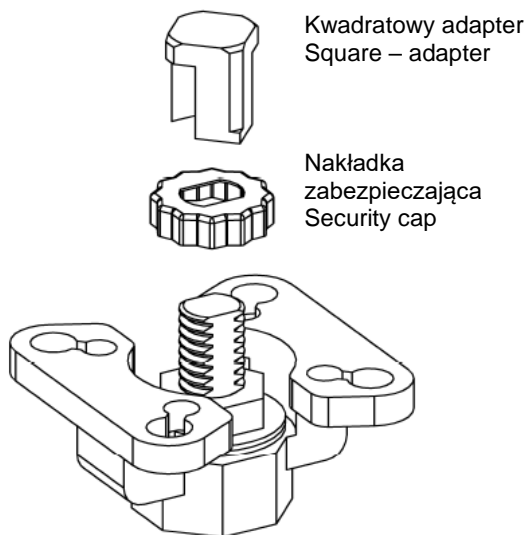

DG1		FG										Kwadratowy adapter / Square-adapter				
DN (F)	DN (R)	DN (F)	H1	LK1	LK2	ØM1	ØP1	ØP2	SW	V	ØZ	DIN 3337 ISO 5211	□S2	H2	□S3	H3
8 / 10	15	-	7	36	42	8	6	6	5,5	3,5	26	F03/F04	9	10	11	12
15 - 25	20 - 32	15 / 20	8	42	50	9	6	7	7	3	26	F04/F05	11	12	14	16
32 / 40	40 / 50	25 / 32	9	42	50	11	6	7	8	3,5	31	F04/F05	11	12	14	16
50	65	40 / 50	13	50	70	14	7	9	10	4,5	36	F05/F07	14	16	17	19

(F) = pełny przelot / full bore

(R) = zredukowany przelot / reduced bore

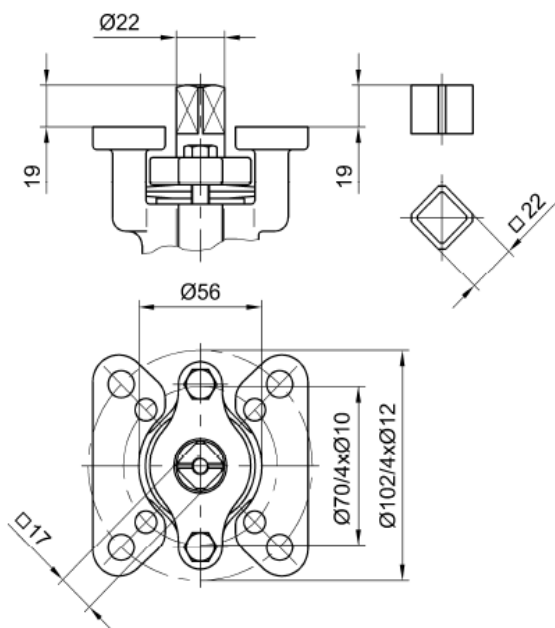
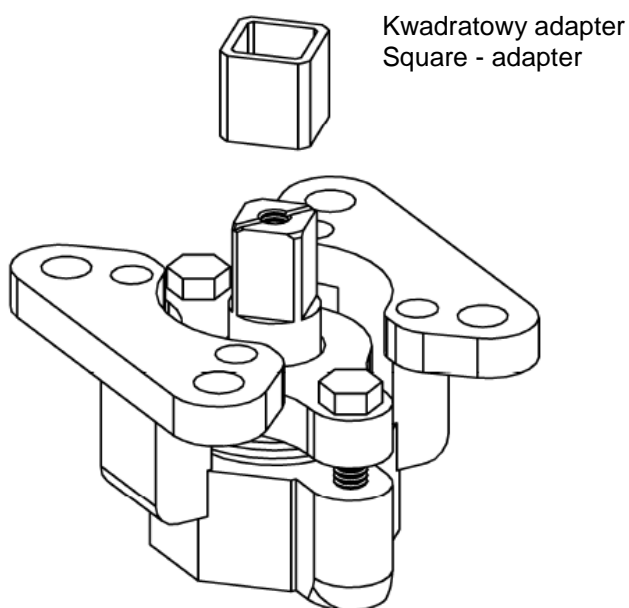

DG1: DN 65 (F) - DN 100 (F)
 DN 80 (R) - DN 150 (R)
 FG: DN 65 (F) - DN 100 (F)

DIN 3337 / ISO 5211: F07 / F10