

Nr części Part No.	Opis Description	Materiał HG144443TGP	HG166663TGP	HG144443MP	HG166353MP	HG144443HMP	HG166353HMP
maks. temperatura robocza ** max. working temperature **		+ 205 °C				+ 324 °C	
1	Korpus Body	GS-C25	1.4408	GS-C25	1.4408	GS-C25	1.4408
2	Tarcza Disc	GS-C25 niklowana/ nickel-plated	1.4408	GS-C25 niklowana/ nickel-plated	1.4408 azotow/nitrated	GS-C25 niklowana/ nickel-plated	1.4408 azotow/nitrated
3	Wał Stem	1.4021	1.4571	1.4021	1.4571	1.4021	1.4571
4*	Pierścień uszczel. Seat	PTFE/szkło PTFE/glass	PTFE/szkło PTFE/glass	1.4571 azotow/nitrated	1.4571 azotow/nitrated	1.4571 azotow/nitrated	1.4571 azotow/nitrated
5	Tuleja łożyskowa Bearing	1.4401 PTFE	1.4401 PTFE	1.4401 PTFE	1.4401 PTFE	1.4401 azotow/nitrated	1.4401 azotow/nitrated
6*	Pakunek Gland packing	PTFE	PTFE	PTFE	PTFE	Grafit graphite	Grafit graphite
7	Pierścień zaciskowy Insert ring	Stal węglowa Carbon steel	1.4571	Stal węglowa Carbon steel	1.4571	Stal węglowa Carbon steel	1.4571
8	Dławica Gland	1.4305	1.4305	1.4305	1.4305	1.4305	1.4305
9*	O-ring	FPM	FPM	FPM	FPM	Chemraz 615	Chemraz 615
10*	O-ring	FPM	FPM	FPM	FPM	Chemraz 615	Chemraz 615
11*	Dolna uszczelka Bottom flange seal	FEP/FPM	FEP/FPM	FEP/FPM	FEP/FPM	Grafit graphite	Grafit graphite
12*	O-ring	FPM	FPM	FPM	FPM	Chemraz 615	Chemraz 615

* = części zużywające się / wearing parts

** = w zależności od ciśnienia / depending on working pressure

Wybór innego materiału na zapytanie
Other materials available

Wymiary przepustnicy serii HG1 DN 350 – DN 500

ul. Zakładowa 4D 62-510 Konin, Tel. 63 245 34 79, E-mail: gefa@hydro-tech.pl

Dł. zabudowy EN 558-1 Typoszereg 20 (DIN 3202-K1)
Podkładka montażowa: ISO 5211

Face to face dimension: EN 558-1 line 20 (DIN 3202-K1)
Mounting plate: ISO 5211

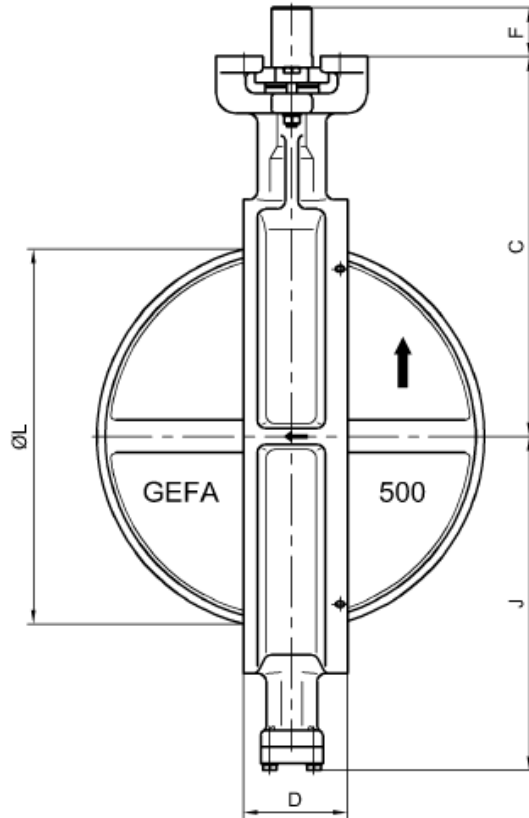
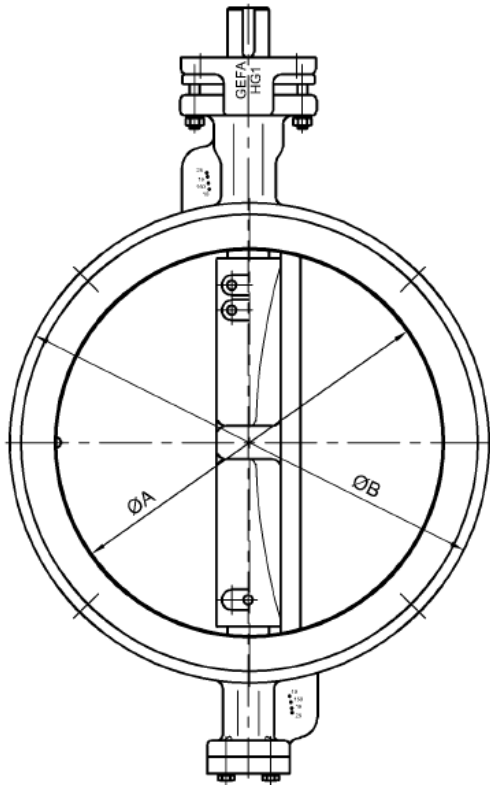

ØL = minimalna średnica wewnętrzna kołnierza /
smallest inside diameter of flange

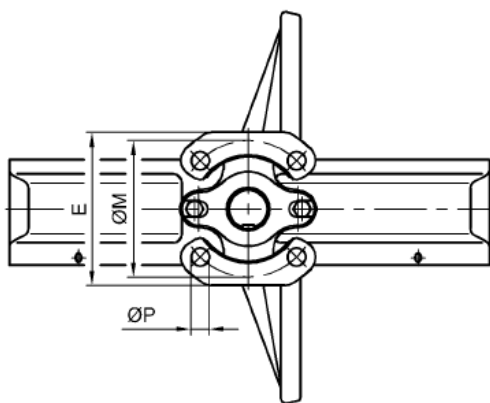

DN 350

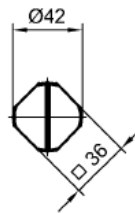

DN 400 / DN 500

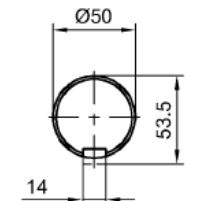

Walek z wpustem / Key
DIN 6885

DN	NPS	ØA	ØB	C	D	E	F	J	ØL	M	nxØP	Podkładka montaż. Mounting plate ISO 5211	kg
350	14"	318	415	365	78	145	38	312	321	140	4x18	F 14	51
400	16"	362	470	405	102	185	60	351	363	165	4x22	F 16	79
500	20"	467	580	465	127	185	60	409	468	165	4x22	F 16	118

Dł. Zabudowy: EN 558-1 Typoszereg 20 (DIN 3202-K1)
Podkładka montażowa: F16 wg ISO 5211

Face to face dimension: EN 558-1 line 20 (DIN 3202-K1)
Mounting plate: F16 acc. to ISO 5211

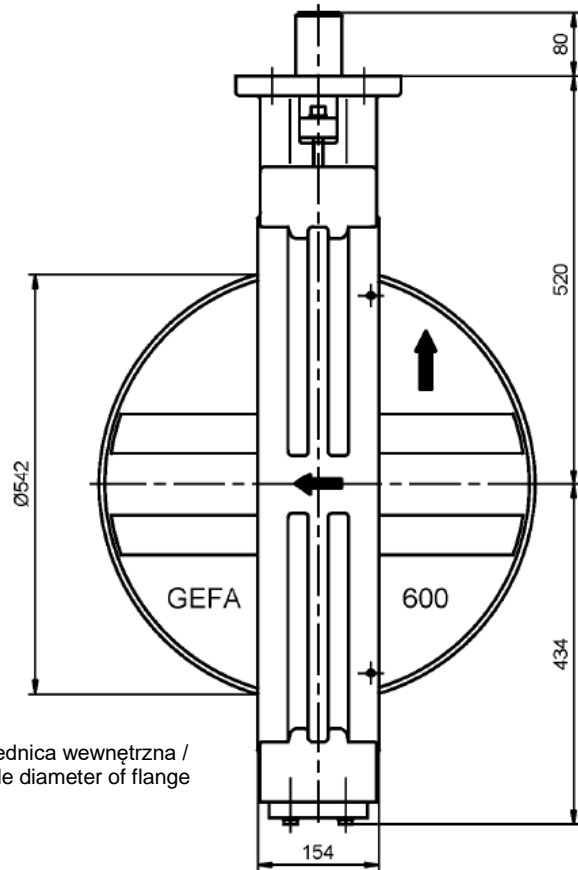
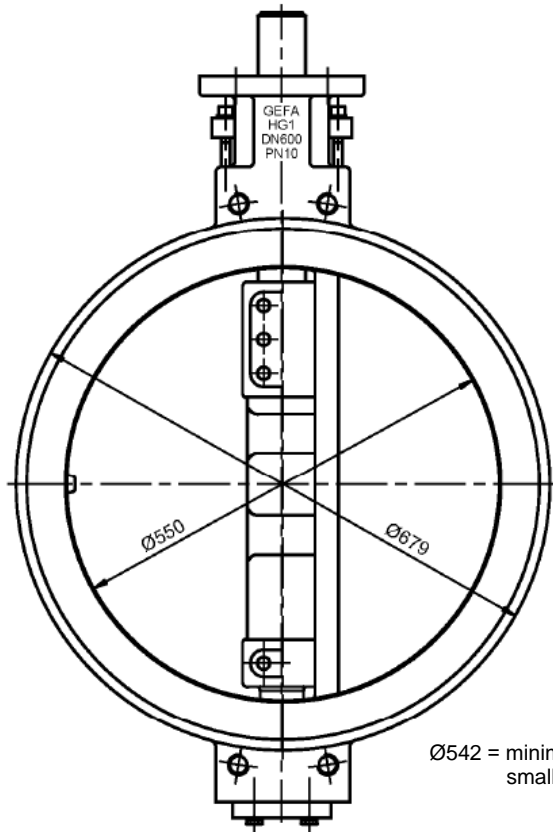

Ø542 = minimalna średnica wewnętrzna /
smallest inside diameter of flange

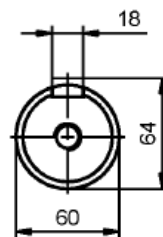
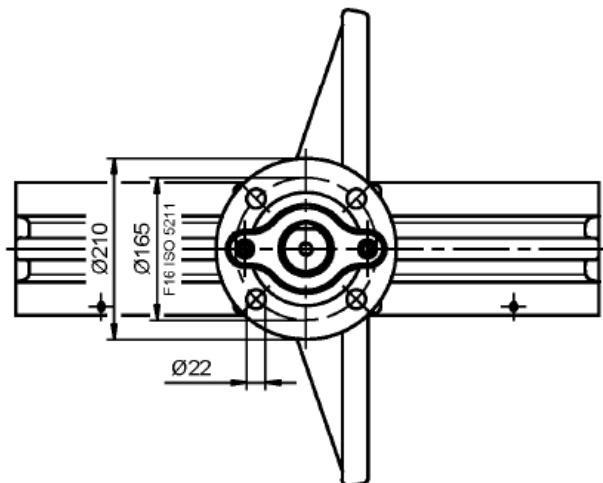

Walek z wpustem / Key
DIN 6885

Opcjonalne przyłącze
kwadratowe
Optional square -
connection

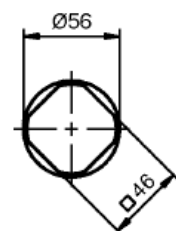
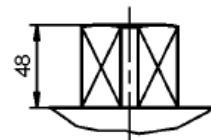

Waga / weight: 225kg

Wymiary przepustnicy serii HG1 z żeliwną przekładnią ślimakową BGPQ DN 350 – DN 600

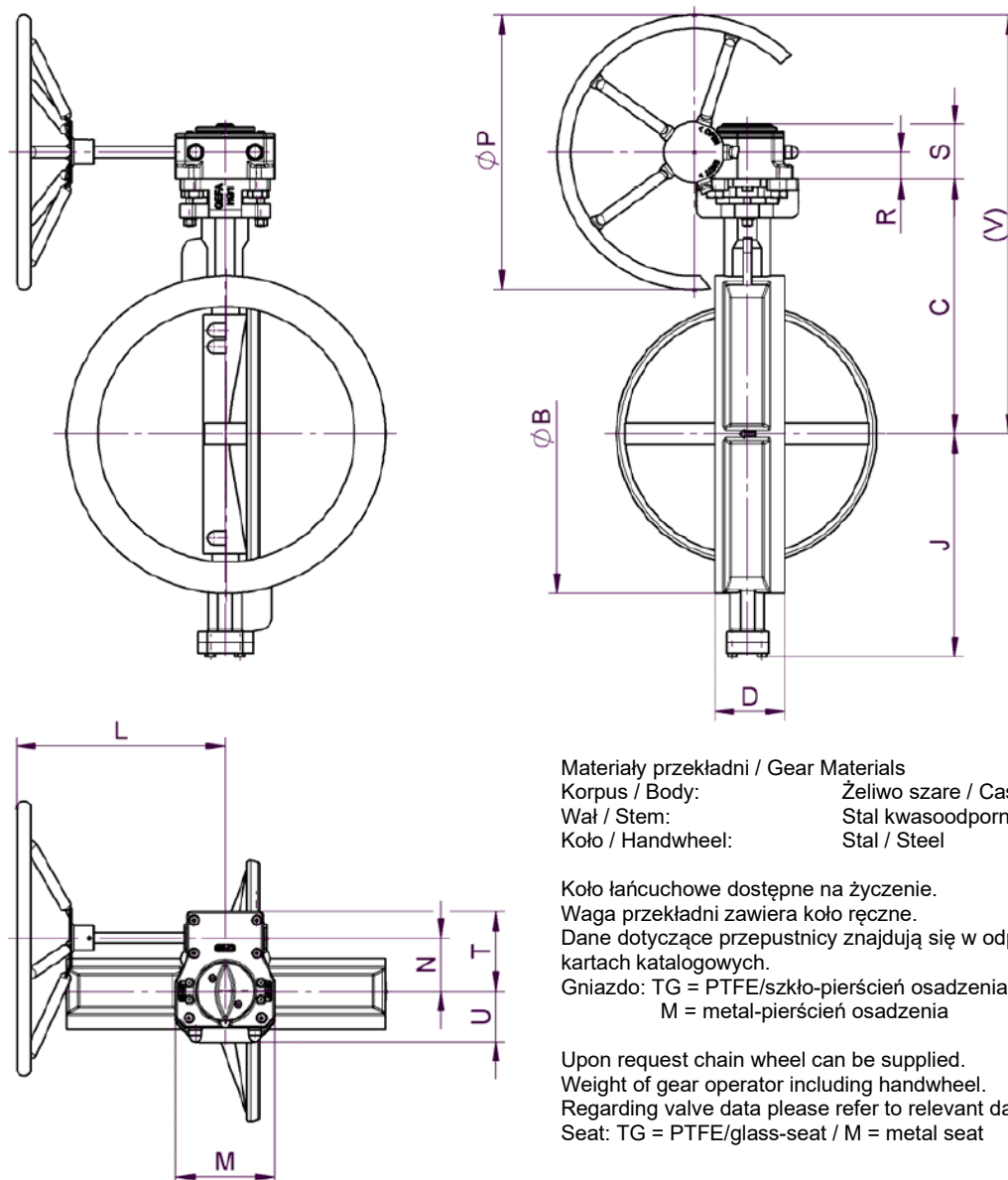

Materiały przekładni / Gear Materials

Korpus / Body: Żeliwo szare / Cast iron
 Wał / Stem: Stal kwasoodporna / Stainless steel
 Koło / Handwheel: Stal / Steel

Koło łańcuchowe dostępne na życzenie.

Waga przekładni zawiera koło ręczne.

Dane dotyczące przepustnicy znajdują się w odpowiednich kartach katalogowych.

Gniazdo: TG = PTFE/szkło-pierścień osadzenia

M = metal-pierścień osadzenia

Upon request chain wheel can be supplied.

Weight of gear operator including handwheel.

Regarding valve data please refer to relevant data sheets.

Seat: TG = PTFE/glass-seat / M = metal seat

DN	NPS	Gniazdo Seat	Typ przekładni Gear type	ØB	C	D	J	L	M	N	ØP	R	S	T	U	V	kg
350	14"	TG/M	BGPQ1500S36V40020	415	365	78	312	309	156	84	400	45	97	123	83	610	12,5
400	16"	TG/M	BGPQ2000S5050020	470	405	102	351	379	180	97	500	50	100	144	92	705	16,5
500	20"	TG	BGPQ2000S5050020	580	465	127	409	379	180	97	500	50	100	144	92	765	16,5
500	20"	M	BGPQ3000S5050020	580	465	127	409	383	250	118	500	49	118	163	115	764	27,0
600	24"	TG/M	BGPQ4000S6050020	679	520	154	434	408	282	138	500	55	128	186	140	825	37,0

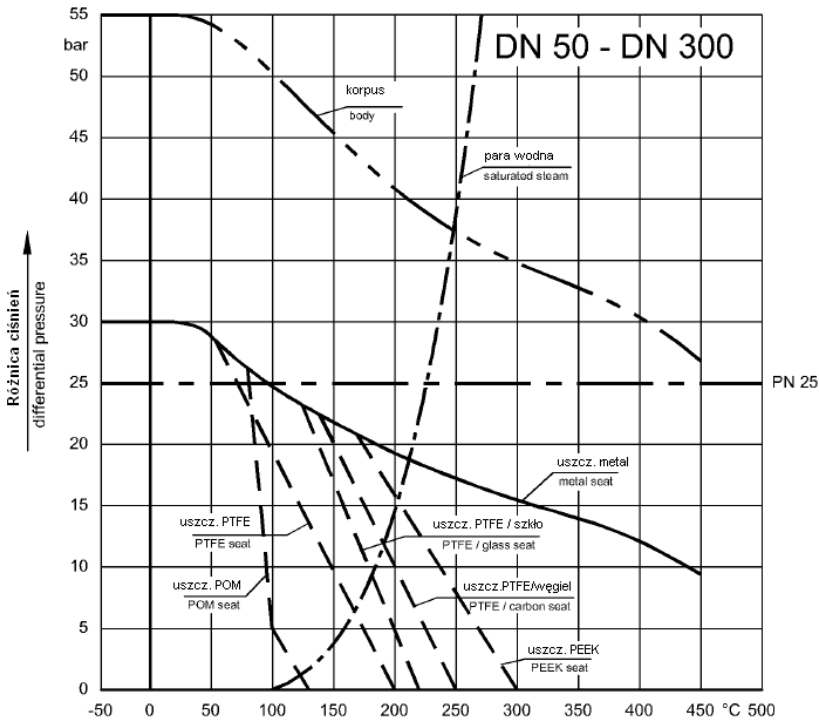

Uszczelnienie metalowe:

Temperatura: >280°C

Klasa szczelności:

DIN 3230-BO >2

EN 12266-P12 >B

Metal seat:

Temperature: >280°C

Seat leakage:

DIN 3230-BO >2

EN 12266-P12 >B

Maksymalna różnica ciśnień dla uszczelnień PEEK i POM wynosi 5 bar, jeśli przepustnica jest zainstalowana przeciwnie do sugerowanego kierunku przepływu.

The maximum differential pressure for PEEK or POM seats is 5 bar if the valve is used against the recommended flow direction.

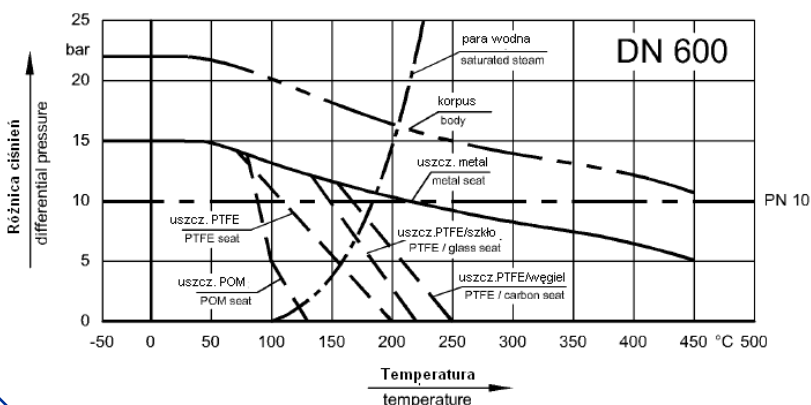
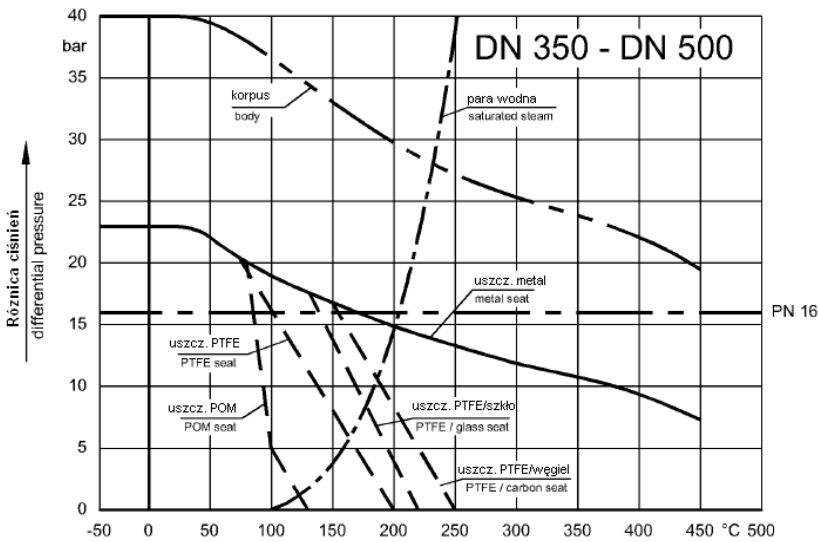

DN	NPS	Moment obrotowy PTFE-gniazdo Torque PTFE-seat $\Delta p = 10$ bar Nm	Moment obrotowy PTFE-gniazdo Torque PTFE-seat $\Delta p = 16$ bar Nm	Moment obrotowy PTFE-gniazdo Torque PTFE-seat $\Delta p = 25$ bar Nm	Moment obrotowy Metal-gniazdo PEEK-gniazdo Torque metal-seat peek-seat $\Delta p = 10$ bar Nm	Moment obrotowy Metal-gniazdo PEEK-gniazdo Torque metal-seat peek-seat $\Delta p = 16$ bar Nm	Moment obrotowy Metal-gniazdo PEEK-gniazdo Torque metal-seat peek-seat $\Delta p = 25$ bar Nm
50	2"	53	55	59	70	72	73
65	2 1/2"	53	55	59	70	72	73
80	3"	55	60	66	78	80	86
100	4"	70	77	88	92	97	106
125	5"	93	104	130	131	143	156
150	6"	131	144	181	179	196	214
200	8"	204	224	280	256	281	318
250	10"	290	319	398	340	378	433
300	12"	418	535	685	536	681	854
350	14"	627	819	—	873	1219	—
400	16"	943	1252	—	1316	1851	—
500	20"	1461	1986	—	2044	2818	—
600	24"	2282	—	—	3219	—	—

Firesafe: PTFE + 10%

Przy doborze napędu nie zaleca się brania pod uwagę dodatkowego współczynnika kontrolnego.

Dane momentu obrotowego nie dotyczą medium typu smar.

W przypadku smarów wartość redukujemy o ok. 20 %.

An additional security factor is not necessary for actuator selection.

The torque data refer to non-lubricating media.

For lubricating media the torques can be reduced by approx. 20 %.

DN	NPS	Kąt otwarcia kłapy Degree of disc rotation								
		10°	20°	30°	40°	50°	60°	70°	80°	90°
50	2"	3	12	24	37	48	57	66	73	79
65	2 1/2"	5	21	40	62	79	94	109	121	130
80	3"	7	26	51	79	101	120	139	159	166
100	4"	17	63	121	188	240	286	331	367	395
125	5"	19	72	131	197	262	340	485	600	655
150	6"	22	85	142	223	325	445	635	790	858
200	8"	80	192	335	475	655	935	1250	1600	1810
250	10"	114	277	480	686	945	1350	1740	2310	2610
300	12"	180	430	745	1065	1470	2090	2790	3590	4050
350	14"	220	530	920	1315	1810	2580	3450	4420	5000
400	16"	305	730	1270	1815	2500	3570	4760	6110	6900
500	20"	530	1270	2210	3160	4340	6200	8280	10600	12000
600	24"	790	1910	3310	4730	6520	9300	12400	15950	18000

K_v = wielkość przepływu w m^3/h przy stratach ciśnienia 1 bar dla wody ($\rho=1000 \text{ kg/m}^3$)

K_v = Water flow ($\rho=1000 \text{ kg/m}^3$) in m^3/h passing through the valve at a pressure drop of 1 bar

C_v = wielkość przepływu w US gal/min przy stratach ciśnienia 1 psi dla wody ($\rho=1000 \text{ kg/m}^3$)

C_v = Water flow ($\rho=1000 \text{ kg/m}^3$) in US gal/min passing through the valve at a pressure drop of 1 psi

$C_v = K_v \times 1,16$

Formuła obliczenia wartości K_v - / Basic formula for calculation of K_v -value

Różnica ciśnień pressure drop	Ciecz liquid	Gaz gas	Para steam
$p_2 > \frac{p_1}{2}$ $\Delta p < \frac{p_1}{2}$	$K_v = Q \cdot \sqrt{\frac{\rho}{1000 \cdot \Delta p}}$	$K_v = \frac{Q_N}{514} \cdot \sqrt{\frac{\rho_N \cdot (t_1 + 273^\circ)}{\Delta p \cdot p_2}}$	$K_v = \frac{G}{31,6} \cdot \sqrt{\frac{v_2}{\Delta p}}$
$p_2 < \frac{p_1}{2}$ $\Delta p > \frac{p_1}{2}$	$K_v = Q \cdot \sqrt{\frac{\rho}{1000 \cdot \Delta p}}$	$K_v = \frac{2 \cdot Q_N}{514 \cdot p_1} \cdot \sqrt{\rho_N \cdot (t_1 + 273^\circ)}$	$K_v = \frac{G}{31,6} \cdot \sqrt{\frac{2 \cdot v}{p_1}}$

Q (m^3/h)

wielkość przepływu w stanie pracy

Flow during operation

Q_N (m^3/h)

wielkość przepływu przy 0 °C, 1013,3 mbar

Flow at 0 °C, 1013,3 mbar

G (kg/h)

przepływ masy

Mass flow

p_1 (bar)

ciśnienie na wejściu

abs. inlet pressure

p_2 (bar)

ciśnienie na wyjściu

abs. outlet pressure

Δp (bar)

różnica ciśnień (p_1-p_2)

Pressure drop (p_1-p_2)

ρ (kg/m^3)

gęstość w stanie pracy

Specific gravity of fluid during operation

ρ_N (kg/m^3)

gęstość przy 0 °C, 1013,3 mbar

Specific gravity of fluid at 0 °C, 1013,3 mbar

v_2 (m^3/kg)

specyficzna objętość przy p_2

Specific volume at p_2

v (m^3/kg)

specyficzna objętość przy $p_1/2$ i t_1

Specific volume at $p_1/2$ and t_1

t_1 (°C)

temperatura robocza

Working temperature